

**ISTRUZIONI DI MONTAGGIO**  
FITTING INSTRUCTIONS  
INSTRUCTIONS DE MONTAGE  
MONTAGEANLEITUNG  
INSTRUCCIONES DE MONTAJE  
ИНСТРУКЦИЯ ПО УСТАНОВКЕ

DISPOSITIVO DI TRAINO TIPO TOWING DISPOSAL TYPE TYPE DU DISPOSITIF DE REMORQUAGE ANHÄNGERVORRICHTUNG TYP DISPOSITIVO DE CAREO TIPO ТЯГОВО-ЦЕПНОЕ УСТРОЙСТВО	<b>37023</b>
PER AUTOVEICOLI FOR CARS POUR VÉHICULES AUTOMOBILES FÜR KRAFTFAHRZEUGE PARA AUTOVEHICULO ДЛЯ АВТОМОБИЛЕЙ	<b>SUZUKI SWIFT</b> 2006 => (EZ)
CLASSE E TIPO DI ATTACCO CLASS AND HITCH TYPE CLASSE ET TYPE DE CROCHET KLASSE UND BEFESTIGUNGSART CLASES DE ACOPLAMIENTO КЛАСС И ТИП СОЕДИНЕНИЯ	F
OMOLOGAZIONE HOMOLOGATION HOMOLOGATION ZULASSUNG APROBACION ОМОЛОГАЦИЯ	e3 00 – 7336 (DIR. 94/20/CE)
CARICO VERTICALE MAX S VALUE MASSE VERTICALE MAXIMUM ZUL. STÜTZLAST CARGA MAX. VERTICAL МАКСИМАЛЬНАЯ ВЕРТИКАЛЬНАЯ НАГРУЗКА	S = kg 70
VALORE D D VALUE VALEUR D D WERT VALOR D ЗНАЧЕНИЕ	$D = \frac{\begin{matrix} \text{Max } \downarrow \text{ Kg} \\ \text{---} \times \text{---} \\ \text{Max } \downarrow \text{ Kg} \end{matrix}}{\begin{matrix} \text{Max } \downarrow \text{ Kg} \\ \text{---} + \text{---} \\ \text{Max } \downarrow \text{ Kg} \end{matrix}} \times 0,00981 \leq \text{kN } 6,2$
COPPIA DI SERRAGGIO PER VITI (8.8): TORQUE SETTINGS FOR NUTS AND BOLTS (8.8): COUPLE DE SERRAGE POUR VIS (8.8): SCHRAUBENZUGSMOMENT (8.8): MOM. DE PRESION PARA TORNILLOS Y TUERCAS (8.8): СПИСОК ДЕТАЛЕЙ (8.8):	M6 = Nm 10                      M8 = Nm 25 M10 = Nm 55                    M12 = Nm 85 M14 = Nm 135                  M16 = Nm 200

## SAFETY INSTRUCTIONS



- ◆ Make sure that the tow bar is suitable for the vehicle before starting the installation. Verify also that the vehicle's towing disposal quoted on the car registration is mentioned on the tow bar document. Otherwise ask the proper office ([umbrarimorchi@umbrarimorchi.it](mailto:umbrarimorchi@umbrarimorchi.it)) for explanation or updated documents.
- ◆ For safety, all work involving tow bar installation must be undertaken by skilled technicians.
- ◆ Damaged components must be replaced with manufacturer's spares parts by qualified staff.
- ◆ It is forbidden to make any modification or structural repair to the tow bar.

## USE AND MAINTENANCE

- ◆ The tow ball must be kept clean and lubricated. For added safety, his diameter (50 mm) must be checked at regular intervals. If the tow ball measures less than 49 mm after selected readings across the diameter, the tow ball must be replaced with a new one.
- ◆ After 1000 km of towing, check torque settings for nuts and bolts, in accordance with the table.

## CAUTION

The towbar installer must fix at the same level with the ball in a clear position, a plate with the ball's maximum load for the vehicle on which the tow bar is fitted.



	37023	03/12/14 v. 1.0	P. 2 / 7
			

# FITTING INSTRUCTIONS

## 37023

Remove from below the vehicle any protective sealant from the points of contact between the shell and the tow bar; then paint the uncovered parts with rust preventer. The holes for the tow bar's fixing some need to be partially done.

1. Disassemble the fitting components of the rear bumper's lower side, to allow through the tow beam.
2. Unfasten the exhaust pipe from the respective support and then lower it.
3. Disassemble the luggage compartment's inner cladding.
4. Loosen the lower side of the fenders's plastic cladding.
5. From inside the luggage compartment place component "F" in correspondence to the existing point "4" and benchmark point "5".
6. Remove component "F" and drill some belt loops of Ø11mm in correspondence to benchmarks "4" and "5". **PAY ATTENTION TO THE PETROL TANK'S TUBES.**
7. Within the luggage compartment widen only the upper side of holes "4" to Ø18mm and insert spacers "B", reallocate component "F" and insert screws fixing only in position "5".
8. From inside the luggage compartment place component "C" in correspondence to the existing point "6" and benchmark point "7" and "1". **WARNING: VERIFY THAT THE DISTANCE BETWEEN POINT "4" AND "1" IS THE SAME SHOWN IN THE ENCLOSED LAYOUT.**
9. Remove component "C" and drill some belt loops of Ø11mm in correspondence to benchmarks "1", "6" and "7".
10. Reallocate component "C" in correspondence to holes "1", "6" and "7"; insert screws and fix only in position "7".
11. From underneath the vehicle place component "D" with reference to holes "4" and component "E" with reference to holes "1" and "6"; fix interjecting the wide washers in position "4".
12. Place tow beam "A" between components "D" and "E" with reference to holes "2" and "3"; insert screws and then fix.
13. Tighten all bolts and nuts with a tightening torque as shown in the enclosed layout.
14. Connect the wiring to the socket (usually given apart), following the car booklet's instructions "*use and maintenance*" as shown in the enclosed wiring kit layout.
15. Reassemble the luggage compartment's inner cladding.
16. Tighten the screws to fix the lower side of the plastic cladding's fenders.
17. Reassemble the exhaust pipe and the components to fix the rear bumper's lower side.

	37023	03/12/14 v. 1.0	P. 3 / 7
			

37023

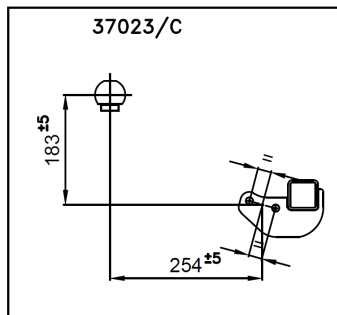
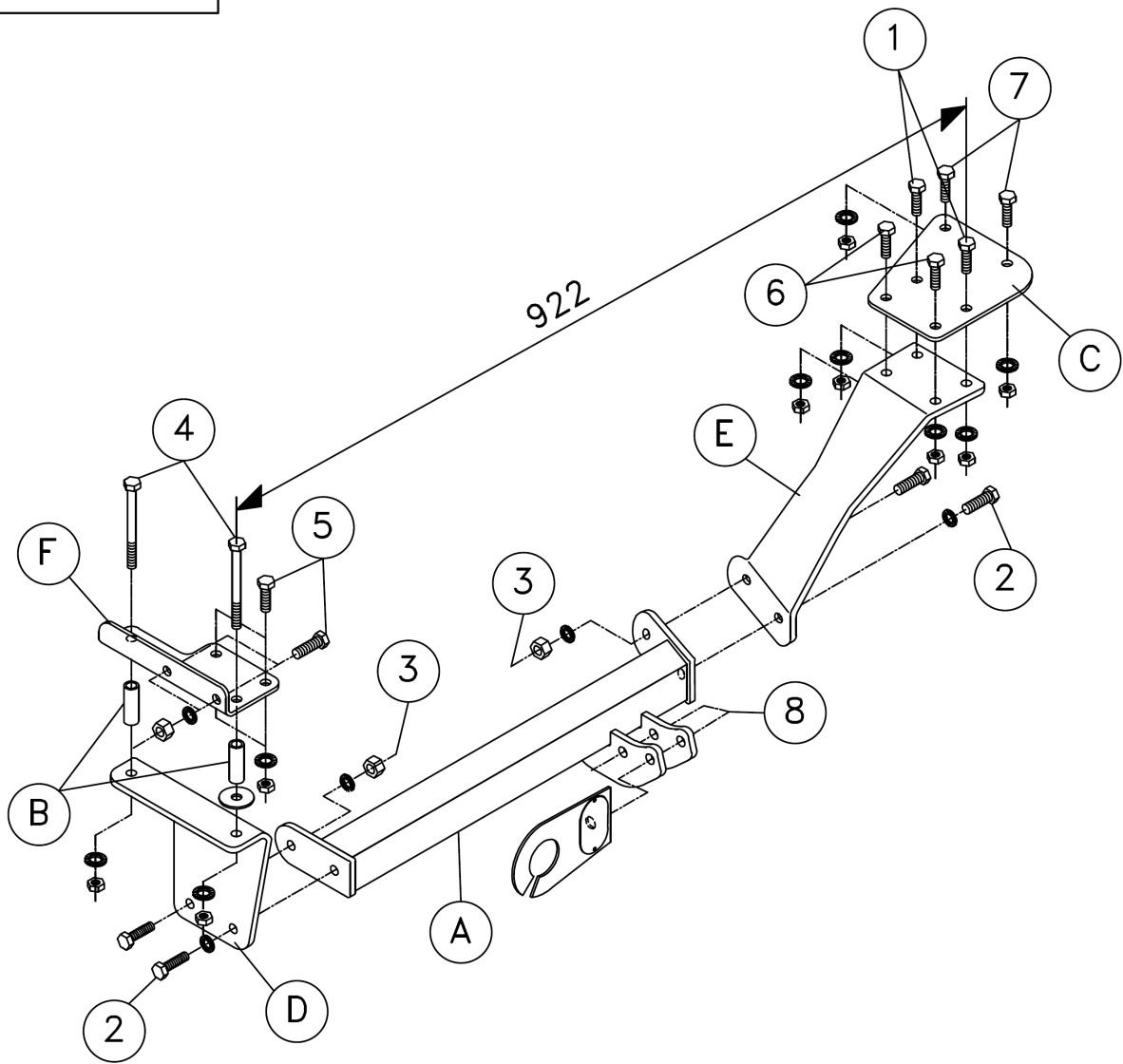























37023





03/12/14 v. 1.0

P. 4 / 7



①	2x		M10x30		CONTACT 10x22x1,5		M10				
②	2x		M10x30		CONTACT 10x22x1,5						
③	2x		M10x30		CONTACT 10x22x1,5		M10				
④	2x		M10x85		ø17x2 Lg. 51mm		N. 1 10x40x2		CONTACT 10x22x1,5		M10
⑤	4x		M10x20		CONTACT 10x22x1,5		M10				
⑥	2x		M10x30		CONTACT 10x22x1,5		M10				
⑦	2x		M10x20		CONTACT 10x22x1,5		M10				

8

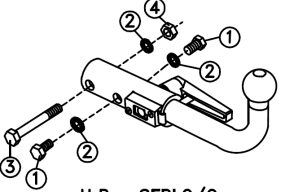
37023/C			
①	2x	M12x25 (8.8)	
②	3x	12.2x27x2.5	
③	1x	M12x85 (8.8)	
④	1x	M12 (8.8)	
			
U.R. SFBLC/G e3 00-7137 (21 HY)			



37023

03/12/14 v. 1.0

P. 5 / 7



# MECCANISMO MOD. C 2007



tel +39 075 5280260  
 fax +39 075 5287033  
[www.umbra-rimorchi.it](http://www.umbra-rimorchi.it)  
[umbra-rimorchi@umbra-rimorchi.it](mailto:umbra-rimorchi@umbra-rimorchi.it)

NL - Montage	S - Montering	I - Montaggio
GB - Mounting	DK - Tilkobling	
D - Montage	FIN - Asennus	
F - Montage	E - Montaje	

NL - Demontage	S - Demontering	I - Smontaggio
GB - Disounting	DK - Frakobling	
D - Demontage	FIN - Irrota	
F - Démontage	E - Desmontaje	

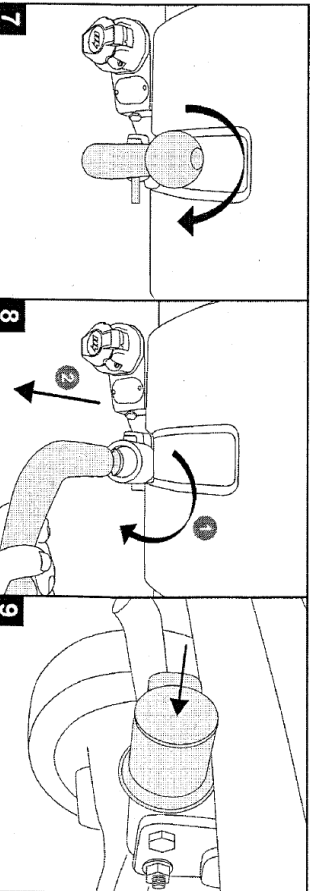
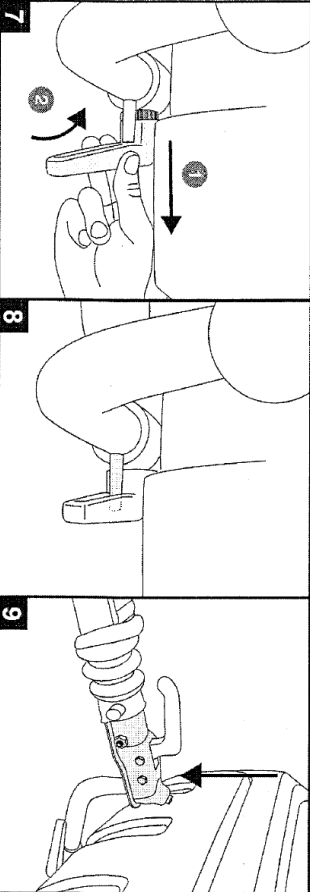
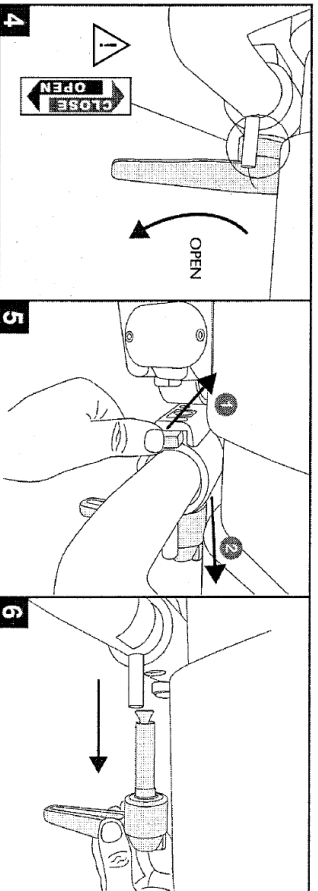
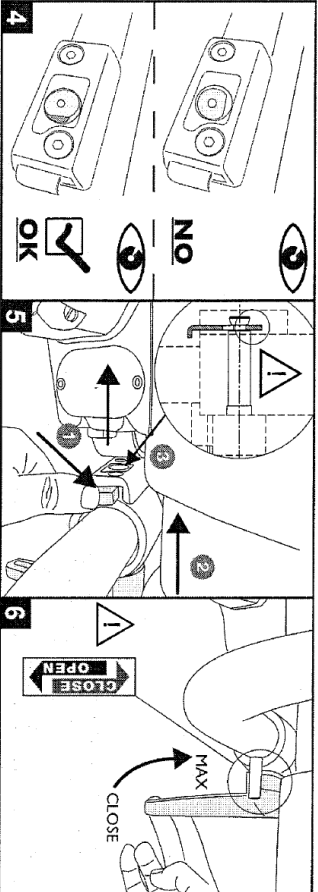
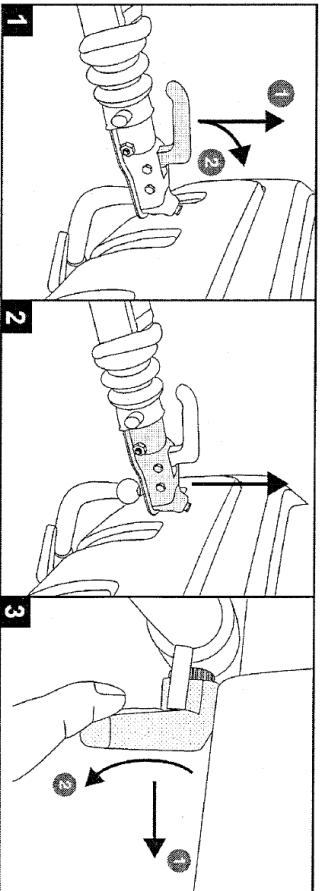
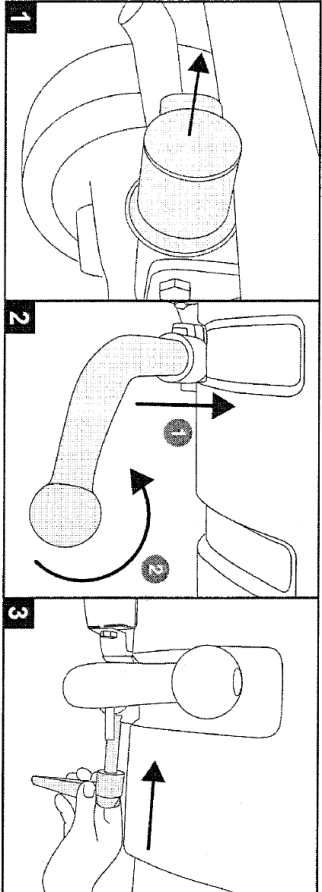

37023

03/12/14 v. 1.0

P. 6 / 7





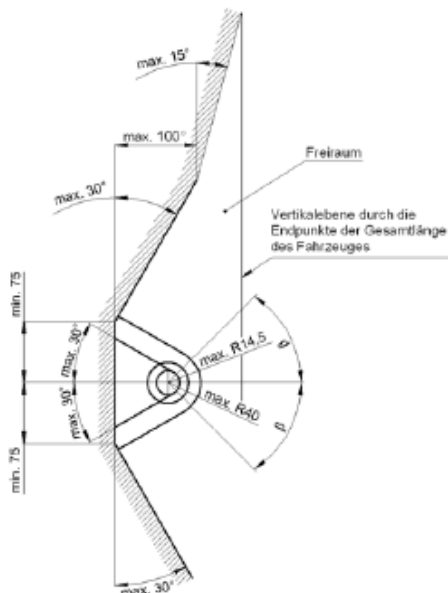
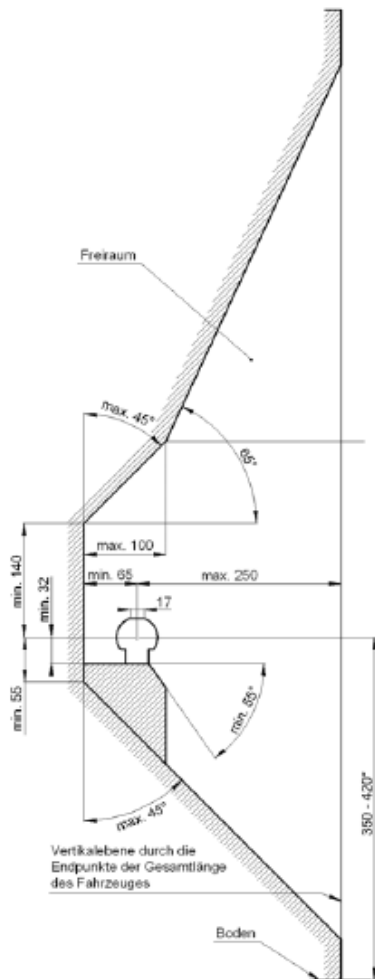

- D** Der Freiraum nach Anhang 7, Abbildung 25a und 25b der Richtlinie ECE-R 55 ist zu gewährleisten.
- CZ** Volný prostor ve smyslu Přílohy VII, obr. 25a a 25b směrnice ECE-R 55 musí být zaručen.
- DK** Det skal sikres, at der er spillerum i overensstemmelse med bilag 7, fig. 25a og 25b i henhold til direktiv ECE-R 55.
- E** Hay que garantizar el espacio libre conforme al anexo 7, fig. 25a y 25b de la directiva ECE-R 55.
- F** La zone de dégagement, selon l'annexe 7, figure 25a et 25b de la directive ECE-R 55, doit être assurée.
- FIN** Välyksen tulee täyttää ohjeen ECE-R 55 liitteen 7 kuvissa 25a ja 25b ilmoitetut vaatimukset.
- GB** Make sure to provide clearance according to appendix 7, figures 25a and 25b of the ECE-R 55 regulations.
- GR** Πρέπει να εξασφαλίζεται ο ελεύθερος χώρος σύμφωνα με το παράρτημα 7, σχήμα 25a και 25b της κοινοτικής οδηγίας ECE-R 55.
- HU** Biztosítani kell az ECE-R 55 irányelv szerinti, 7. számú függelék, 25a. és 25b ábrákban jelölt szabad teret.
- I** Deve essere garantito lo spazio libero secondo l'allegato VII, figure 25a e 25b della normativa europea ECE 55 R-01.
- N** Det må sikres for fritt rom i samsvar med tillegg 7, figur 25a og 25b i direktiv ECE-R 55.
- NL** De vrije ruimte volgens supplement 7, afbeelding 25a en 25b van richtlijn ECE-R 55 moet gewaarborgd zijn.
- PL** Należy zapewnić wolną przestrzeń zgodnie z załącznikiem 7, rys. 25a i 25b, dyrektywy ECE-R 55.
- RUS** Оставлять свободное пространство согласно Приложению 7, рис. 25a и 25b Директивы ECE-R 55.
- S** Spelrummet enligt bilaga 7, bild 25a och 25b i riktlinje ECE-R 55, måste garanteras.

- D** \* bei zulässigem Gesamtgewicht des Fahrzeuges
- CZ** \* při celkové přípustné hmotnosti vozidla
- DK** \* ved tilladt totalvægt for køretøjet
- E** \* con peso total autorizado del vehículo
- F** \* pour poids total en charge autorisé du véhicule
- FIN** \* Ajoneuvon suurimmalla sallitulla kokonaispainolla
- GB** \* at gross vehicle weight rating
- GR** \* για το επιτρεπτό μικτό βάρος του οχήματος
- HU** \* A jármű megengedett összsúlya esetén
- I** \* per il peso complessivo ammesso del veicolo
- N** \* ved kjøretøyet's tillatte totalvekt
- NL** \* bij toegestaan totaal gewicht van het voertuig
- PL** \* przy dopuszczalnym ciężarze całkowitym pojazdu
- RUS** \* при допустимом общем весе автомобиля
- S** \* vid fordonets tillåtna totalvikt



37023

03/12/14 v. 1.0

P. 7 / 7





[ahkupplungen.de](http://ahkupplungen.de)